

STEP 2 – Assemble the Cross Rail (E) to the recesses in Left Rail (C) and Right Rail (D) using Barrel Nuts (I), and 5/16" x 3-1/4" Hex Bolts with washers (J).

- Identify Cross Rail (E), Barrel nuts (I) and 5/16" x 3-1/4" Hex Bolts with washers (J).
- Refer to Figure 7. Slide the Cross Rail between each of the Rails (C, D) so that it slots into the recesses. The two holes in the Cross Rail should face inward, toward the Upholstered Barrel Assembly. The rails may need to be separated slightly to fit the Cross Rail between them, but be careful they do not disengage the spring-loaded plungers on the insides of the Upholstered Barrel Assembly. If they do slip out and disengage the spring-loaded plungers, go back to Step 1-c and reference Figures 5 and 6 to verify correct position.
- Refer to Figure 8. Insert one Barrel Nut (I) into each hole located on the Cross Rail (E) with the slotted end facing the Upholstered Barrel Assembly. Using a Flathead Screwdriver, rotate the Barrel Nut until the slot is horizontal. Insert one 5/16" x 3-1/4" Hex Bolt with washer (J) through each rail from the outside until it engages the threads of the Barrel Nut. Thread the Hex Bolts into the Barrel Nuts, but do not fully tighten at this time.

STEP 3 – Assemble the Ladder (B) to the L-Brackets on Left and Right Rails (C, D) using 1-1/4" Binding Post Screws (male and female) (F, G).

- Orient the Ladder (B) so that the black, plastic hole plugs near the top are facing outward, away from the Upholstered Barrel Assembly.
- Slide the Ladder between the pre-mounted L-Brackets on each Rail so that the holes are aligned.
- Refer to Figure 9. Carefully squeeze approximately one drop of Loctite into the female Binding Post Screw (G). Use caution with Loctite, it comes out of the tube quickly. Beginning at the left side of the Ladder, insert one 1-1/4" Binding Post Screw (female) (G) from the inside of the Ladder through the L-Bracket and Ladder. From the other side, insert one 1-1/4" Binding Post Screw (male) (F). Using the two 3/16" Allen (Hex) Wrenches included, thread the male and female Binding Post Screws together, but do not tighten. Repeat these steps for the remaining two holes in the L-Bracket on Left Rail (C).
- Move to the three holes in the L-Bracket on Right Rail (D) and repeat the process using the remaining three Binding Post Screws (F, G). Using the two 3/16" Allen (Hex) Wrenches, fully tighten the three sets of Binding Post Screws that attach the Ladder to the L-Brackets on each side.

STEP 4 - Tighten all Fasteners and Insert 3/4" Plastic Hole Plugs (K)

- Using a Socket Wrench with 1/2" Socket, firmly tighten both 5/16" x 3-1/4" Hex Bolts from Step 2. Insert one 3/4" Plastic Hole Plug (K) into each Rail.
- Using the two included 3/16" Allen (Hex) Wrenches, verify that all six (6) sets of Binding Post Screws (F, G) from Step 3 are firmly tightened.

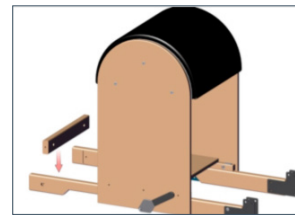

FIGURE 7

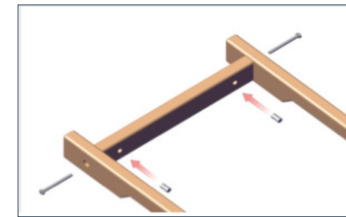

FIGURE 8

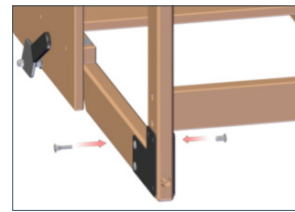

FIGURE 9

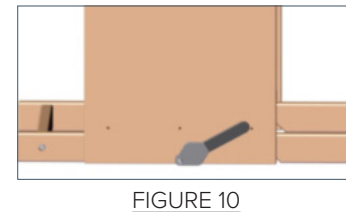

FIGURE 10

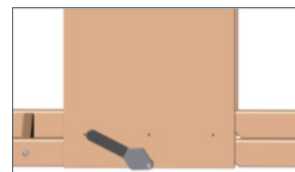

FIGURE 11

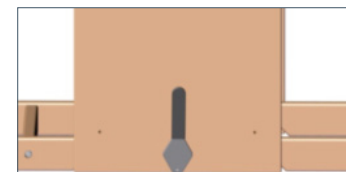

FIGURE 12

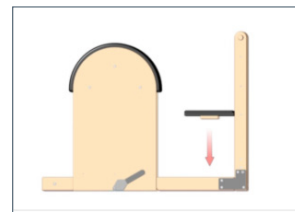

FIGURE 13

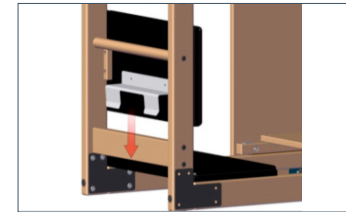

FIGURE 14

STEP 5 – Test Your Assembled High Ladder Barrel

- Your High Ladder Barrel should sit flat on the floor.
- Test the function of the sliding mechanism by unlocking the Lever-Lock on each side of the Upholstered Barrel. Figures 10 and 11 show the Lever-Lock in two possible unlocked positions. After placing the two Lever-Locks are in an unlocked position, push the Upholstered Barrel Assembly back and forth along the rails. The Upholstered Barrel Assembly should slide smoothly with minimal resistance.
- Test the function of the locked position of the Lever-Locks. Refer to Figure 12 and place the Lever-Lock on each side of the barrel in its locked position. When in this position, the Upholstered Barrel Assembly should not slide along the rails.

STEP 6 – Install Flat Foot Plate (OPTIONAL accessory item).

Refer to Figure 13. Set the Flat Foot Plate on to the Rails (C, D), upholstered side facing upward. The wooden cleats on the underside of the Flat Foot Plate slot between the rails and secure it from moving laterally.

STEP 7 – Install Vertical Foot Plate (OPTIONAL accessory item)

Refer to Figure 14. Locate the metal bracket on the back of the Vertical Foot Plate and slide it over the bottom cross-brace on Ladder (B).

The assembly of your High Ladder Barrel is now complete. Please do not hesitate to contact us with any questions at 1-800-925-3674 or info@peakpilates.com

PEAK PILATES
www.peakpilates.com

Mad Dogg Athletics, Inc.
2111 Narcissus Court Venice, CA 90291
USA
(800) 847.7746 or (310) 823.7008
info@peakpilates.com

Mad Dogg Athletics, Inc. Europe
Scheldeweg 3, 3144 ES Maassluis
The Netherlands
+31 1059 04508
CustomerServiceEurope@maddogg.com

PEAK PILATES[®]



THE HIGH LADDER BARREL
ASSEMBLY GUIDE AND OWNER'S MANUAL

RECOMMENDED USE

Peak Pilates strongly recommends consulting a physician for a complete medical exam before beginning any exercise program. Having a complete medical exam is particularly important if the user has a family history of high blood pressure, has heart disease, is over the age of 45, smokes, has high cholesterol, is obese, or has not exercised regularly in the past year.

If, at any time while exercising, the user feels faintness, dizziness, pain, or shortness of breath, he or she must stop immediately.

Important: This manual contains safety and usage information. Before beginning exercise, read the entire manual paying specific attention to all cautions and warnings and obtain qualified instruction on the use of the Peak Pilates High Ladder Barrel. Use only for the intended exercises. Do not modify the equipment. Modifying the equipment will void your warranty. Keep this guide handy for future reference.

Unsafe or improper use of this equipment due to failure to read and comply with all requirements and warnings could result in serious injury. Because Peak Pilates cannot anticipate every situation and condition that can occur while using the Peak Pilates High Ladder Barrel, we make no representation concerning the safety of this equipment.

There are risks associated with the use of any exercise equipment. The user assumes the responsibility for those risks.

Safety Statement

It is the responsibility of the purchaser of the products to instruct all individuals, whether they are end users or supervising personnel, on the proper use of the equipment.

Inspect the equipment on a regular basis, including all hardware, wood, and fabric components before use. Do not exercise on the High Ladder Barrel if signs of excessive wear, loose hardware, or other defects are evident. Do not attempt to fix defective equipment prior to contacting Peak Pilates.

NOTE: We strongly recommend that all users of Peak Pilates exercise equipment be informed of the following prior to use.

Proper Use

1. This equipment is only to be used as described by the manufacturer. It is imperative that the High Ladder Barrel be used properly to avoid injury.
2. Use only components provided by the manufacturer. Do not use parts or accessories or modify the equipment in any way not approved by Peak Pilates.
3. Keep a three foot area (about one meter) around the equipment clear of obstructions.
4. Make sure the equipment is used on a level surface.

Specific Operating Warnings

1. Be certain that all hardware is fully tightened before beginning exercise.
2. Do not tip the equipment during use.
3. Children must not be allowed near this equipment. Teenagers and/or physically challenged individuals require supervision.
4. Make sure that both Lever-Locks are in a locked position prior to use.
5. It is the purchaser's sole responsibility to instruct end users and supervising personnel on the proper operating procedures of the High Ladder Barrel. We strongly recommend that the end user's physical condition be evaluated prior to beginning any exercise program.

NOTE: Understanding each and every warning to the fullest is critical. If any of these warnings is unclear, ask for clarification from Peak Pilates personnel.

WARRANTY

We warrant your purchase to be free of manufacturing defects. Please contact customer service or refer to the written warranty policy accompanying these instructions. Warranty information is also available on our website: www.peakpilates.com

Mad Dogg Athletics®, Inc.
Peak Pilates, 2111 Narcissus Court, Venice, CA 90291
U.S. Toll-Free (800) 847-7746
Outside U.S.: 1 (310) 823-7008 / (Fax) 310-823-7408
info@peakpilates.com

Mad Dogg Athletics® Europe BV
Scheldeweg 3 | 3144 ES Maassluis
The Netherlands
+31 1059 04508
CustomerServiceEurope@maddogg.com

PARTS IDENTIFICATION

Tools Required for Assembly

1. Flathead Screwdriver
2. Socket Wrench with 1/2" Socket
3. 3/16" Allen Wrenches (2, included)

Parts (See Figures 1 & 2)

IDENTIFIER	DESCRIPTION	QUANTITY
A	Upholstered Barrel Assembly w/ Lever Locks	1
B	Ladder	1
C	Left Rail with L-Bracket	1
D	Right Rail with L-Bracket	1
E	Cross Rail	1
F	1-1/4" Binding Post Screw (male)	6
G	1-1/4" Binding Post Screw (female)	6
H	3/16" Allen (Hex) Wrench	2
I	Barrel Nut	2
J	5/16" x 3-1/4" Hex Bolt with washer	2
K	3/4" Plastic Hole Plug	2
M	Loctite-thread locker liquid	2

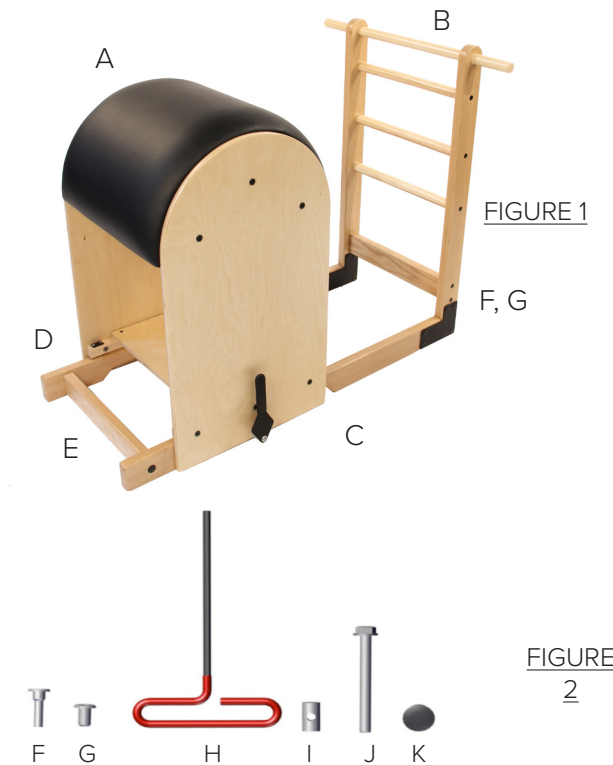

ASSEMBLY INSTRUCTIONS

Thank you for your purchase. Your Peak Pilates High Ladder Barrel is assembled and tested prior to being packed for shipment to ensure that all components assemble correctly.

Carefully unpack the equipment so as not to damage or misplace components. Before discarding any packaging material, assemble the High Ladder Barrel completely. Verify packed contents using the parts list with illustrations found in this assembly guide.

NOTE: Throughout this manual, "right" and "left" sides of the High Ladder Barrel are determined from the perspective of the user leaning back on the Ladder and facing the Upholstered Barrel Assembly.

STEP 1 – Assemble Left and Right Wood Rails with L-Brackets (C, D) to Upholstered Barrel Assembly w/Lever Locks (A).

1. Perform the assembly on a clean, flat surface for best results. Referring to Figure 3, locate the wooden cleats and spring-loaded plungers on the inside of the Upholstered Barrel w/Lever Locks. Also, notice the rubberized strip affixed to the underside of each wooden cleat. Do NOT remove the rubberized strips.
2. Refer to Figure 4. Notice the small rectangular recesses near the ends of each Rail (C, D). Position the rails so that the recesses are on the same end and both face inward to later accept Cross Rail (E).
3. Refer to Figure 5. The Left Rail (C) has a numbered sticker affixed. Attach the Left Rail (C) to the inside of the barrel by angling it as shown and rolling it into position flat against the insides of the barrel. The end of the rail with the recess should be extended as far beyond the Upholstered Barrel Assembly as possible while still fitting into position above the lever lock mechanism.
4. Attach the Right Rail (D) in the same fashion. Once this step is complete, the High Ladder Barrel will be in the state of assembly pictured in Figure 6.

